

CORH

Outside-Collet Chuck

高速弹簧卡盘



产品特点

CORH 卡盘适用于棒料类零件，以及易变形类零件的加工，在高转速下，可以保持卓越的夹持力和优异的精度。

主要技术

快换式分瓣夹头，更换便捷；
可以提供夹持圆形，方形，六角形等夹头

Application / Customer's Benefit

The CORH chuck is I.D clamping chuck which has high surface , also it has strong clamping force during high r.p.m. precision.

Technical features

Quick change rubber -steel segment collet
Round, square and hexagonal collets available

产品规格 / SPECIFICATIONS

		CORH-42B / M	CORH-52B / M	CORH-65B / M
最大夹紧力 [kgf]	Max. Clamping force	8100	4000	4500
最大拉杆拉力 [kgf]	Max. Drawbar Pull	3500	9500	10700
夹头行程 [mm]	Collet Expansion	Φ 1.6	Φ 1.6	Φ 1.6
柱塞行程 [mm]	Plunger Stroke	4.5	4.5	4.5
夹持范围 [mm]	Clamp Dia Range	Φ 5 ~ Φ 42	Φ 5 ~ Φ 52	Φ 5 ~ Φ 62
最大转速 [r.p.m.]	Max. Speed	7000	7000	6000
重量 [kg]	Weight	10	10	10
夹头型号	Clamping Head	HZM42	HZM52	HZM65
卸套器型号	Clamping head Tool	EK42/52		EK65

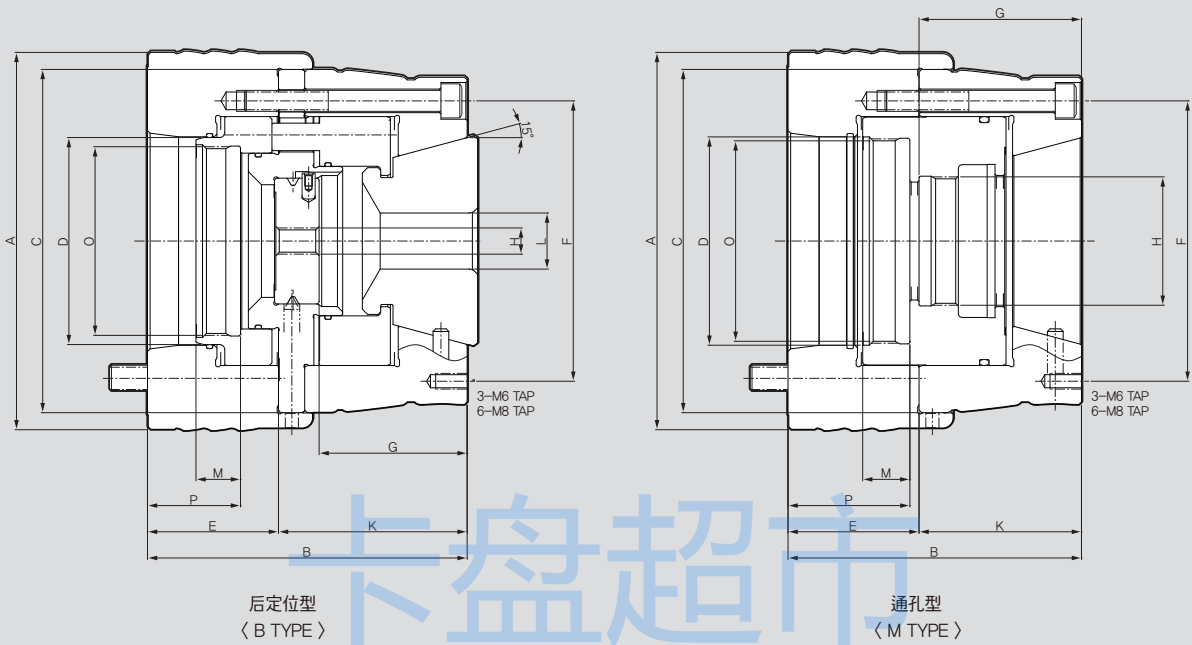

产品尺寸 / DIMENSIONS

	CORH-42B / M	CORH-52B / M	CORH-65B / M
ΦA	144	144	160
B	122 / 112	122 / 112	131 / 121
ΦC	131	131	148
ΦD	79 / 79.5	79 / 79.5	79 / 79.5
E	50	50	52
ΦF	107	107	126
G	56.5 / 64	56.5 / 64	63.5 / 67.5
H	M10 / M49 X 1.5p	M10 / M60 X 1.5p	M12 / M72 X 1.5p
K	72 / 62	72 / 62	79 / 69
ΦL max.	42	52	65
ΦL min.	5	5	5
ΦM	17 / 18	17 / 16	18
O	M72 X 1.5p / M78 X 1.5p	M72 X 1.5p / M78 X 1.5p	M72 X 1.5p / M78 X 1.5p
P max.	38.0 / 49.0	38.0 / 47.0	36.0 / 52.0
P min.	33.5 / 44.5	33.4 / 42.5	32.0 / 47.5