

CT 3-JAW ADJUSTMENT STEEL BODY SCROLL CHUCKS

可調式普通型三爪鋼殼夾頭

尺寸圖 » Dimensions

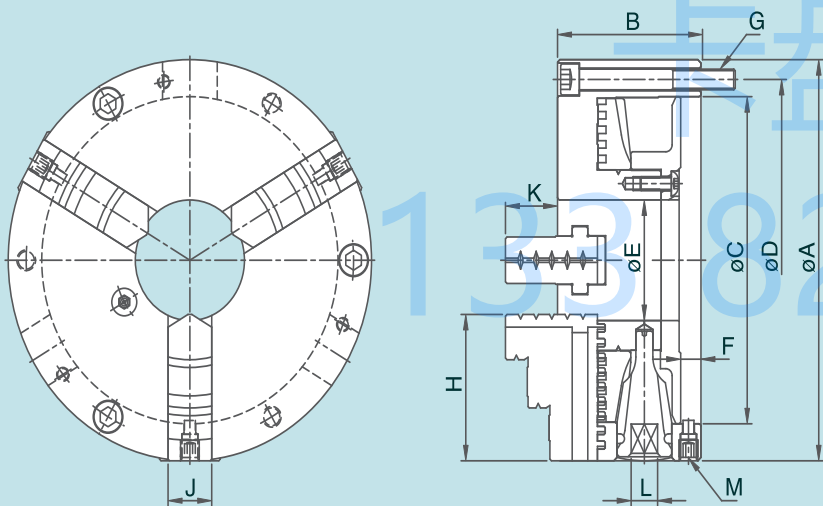

規格表 » Specifications

單位/UNIT:mm

| 型式/規格 MODEL / SPEC. | A | B | C | D | E | F | G | H | J | K | L | M | 最高迴轉速 Max.Speed r.p.m.(min ⁻¹) | 把握範圍 Max. Gripping Diameter | | 淨重 Weight (kg) |
|---------------------------|-----|------|-----|-----|-----|------|-------------|-----|----|------|----|-------------|--|-----------------------------|----------------------|----------------------|
| | | | | | | | | | | | | | | 外徑把握 O.D.Clamping | 內徑把握 I.D.Clamping | |
| CT-06 | 167 | 75.5 | 130 | 147 | 45 | 12 | 3-M10x1.5P | 65 | 22 | 28 | 10 | 3-M12x1.75P | 4000 | ø4~ø160 | ø48~ø150 | 10.4 |
| CT-07 | 193 | 85 | 155 | 172 | 58 | 12 | 3-M10x1.5P | 75 | 24 | 28.5 | 11 | 3-M12x1.75P | 3500 | ø4~ø180 | ø56~ø170 | 12.9 |
| CT-09 | 233 | 92 | 190 | 210 | 70 | 12.5 | 3-M12x1.75P | 85 | 28 | 33 | 12 | 3-M12x1.75P | 2900 | ø5~ø220 | ø62~ø210 | 20.4 |
| CT-10 | 275 | 98 | 230 | 250 | 89 | 12.5 | 3-M12x1.75P | 98 | 30 | 38 | 12 | 3-M12x1.75P | 2500 | ø6~ø260 | ø70~ø250 | 29.3 |
| CT-12 | 310 | 111 | 260 | 285 | 105 | 14 | 3-M12x1.75P | 110 | 32 | 45 | 14 | 3-M12x1.75P | 2200 | ø10~ø300 | ø86~ø290 | 43.7 |