

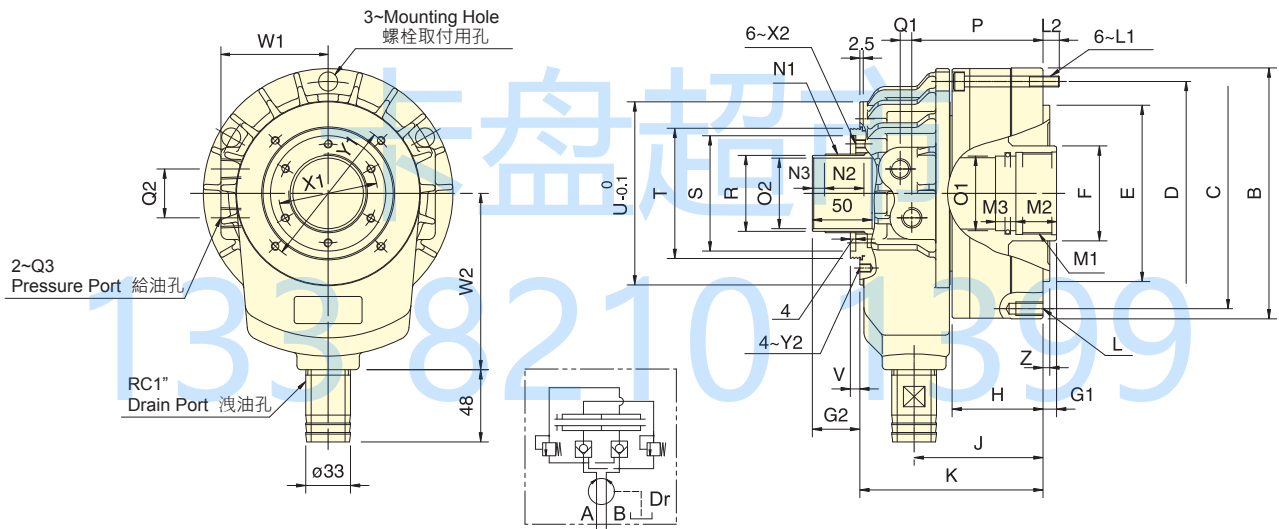

- 超短，大孔徑型迴轉油壓缸，全長僅為從來型的2/3。
 - 內建逆止閥自鎖機構及壓力洩壓閥。
 - 安裝時可由後端鎖固之。
 - Super short form, light weight large Through-Hole, just as 2/3 of typical model length.
 - Built-in safety check valves and pressure relief valves.
 - Can screw it from the rear end of the cylinder when mounting.
- 專利產品字號 Patent numbers :
 台灣 : PAT.NO.M491534(Taiwan)
 大陸 : PAT.NO.ZL201420584274.5(China)



保留規格修改的權利
 Subject to technical changes

技術規格 SPECIFICATIONS

型號 Model	活塞面積 Eff. piston area		行程 Piston stroke	最高迴轉數 Max. speed	最高使用壓力 Max. pressure	I Moment of inertia	重量 Weight	總洩漏量 Total oil leakage
	伸側 (Extend) cm ²	縮側 (Retract) cm ²						
TK-A528	73.0	69.7	12	8000	4.5 (45)	0.012	6.2	3.0
TK-A533	73.0	69.7	12	8000	4.5 (45)	0.012	6.0	3.0
TK-C643	99.1	88.0	15	7000	4.5 (45)	0.018	7.5	3.0
TK-A646	105.0	93.9	15	7000	4.5 (45)	0.018	7.3	3.0
TK-B646	105.0	93.9	15	7000	4.5 (45)	0.018	8.6	3.0
TK-C646	99.1	88.0	15	7000	4.5 (45)	0.018	7.5	3.0
TK-B846	135.3	125.0	20	6300	4.5 (45)	0.032	12.4	3.9
TK-A853	135.3	125.0	20	6300	4.5 (45)	0.032	11.8	3.9
TK-B853	135.3	125.0	20	6300	4.5(45)	0.032	11.7	3.9
TK-1068	165.9	149.9	25	5500	4.5 (45)	0.065	17.8	4.2
TK-A1075	170.0	155.0	25	5500	4.5(45)	0.065	18.8	4.2
TK-A1078	170.1	155.3	25	5500	4.5 (45)	0.065	17.4	4.2

空油壓迴轉缸

外型尺寸 DIMENSIONS

Model	A	B	C	D	E	F	G1		G2		H	J	K	L	L1	L2	M1	M2	M3
	內徑 I.D.				h7		max.	min.	max.	min.									
TK-A528	105	141	125	125	110	45	12	0	38	26	49	77.5	123	6~M8x20	M8x55	14	M38x1.5	25	13
TK-A533	105	141	125	125	110	45	12	0	38	26	49	77.5	123	6~M10x20	M8x55	14	M38x1.5	25	13
TK-C643	128	156	140	140	120	65	15	0	44	29	56	85	125	12~M10x20	M8x60	12	M50x2	25	13
TK-A646	128	162	147	147	130	65	15	0	44	29	56	85	125	12~M10x20	M8x60	12	M55x2	25	13
TK-B646	128	162	130	147	100	65	15	0	44	29	66	95	135	12~M10x20	M8x70	12	M55x2	30	15
TK-C646	125	156	140	140	120	65	15	0	44	29	56	85	125	12~M10x20	M8x60	12	M55x2	25	13
TK-B846	145	185	170	165	130	70	20	0	48	28	66	95	135	12~M10x20	M8x70	12	M55x2	30	15
TK-A853	145	185	170	165	140	70	20	0	48	28	66	95	135	12~M10x20	M8x70	12	M60x2	30	15
TK-B853	145	185	170	165	130	70	20	0	48	28	66	95	135	12~M10x20	M8x70	12	M60x2	30	15
TK-1068	170	212	190	190	160	98	25	0	50	25	73	107	157	12~M10x20	M10x80	17	M75x2	35	15
TK-A1075	170	212	190	190	160	95	25	0	50	25	74	108	158	12~M10x20	M10x80	16	M85x2	35	15
TK-A1078	170	212	190	190	160	95	25	0	50	25	74	108	158	12~M10x20	M10x80	16	M87x2	35	15

Model	N1	N2	N3	O1	O2	P	Q1	Q2	Q3	R	S	T	U	V	W1	W2	X1	X2	Y1	Y2	Z
				H8	H8					g7	H7										
TK-A528	M39x1.5	25	8	35	28	79	8.5	30	RC1/4	37	62	70	98	6	62	110	49	M6x6	83	M5x6	5
TK-A533	M39x1.5	25	8	35	33	79	8.5	30	RC1/4	37	62	70	98	6	62	110	49	M6x6	83	M5x6	5
TK-C643	M52x1.5	29	9	45	43	87	8.5	36	RC3/8	50	76	85	116	6	74	120	64	M6x6	98	M5x6	5
TK-A646	M52x1.5	29	9	50	46	87	8.5	36	RC3/8	50	76	85	116	6	74	120	64	M6x6	98	M5x6	5
TK-B646	M52x1.5	29	9	50	46	97	8.5	36	RC3/8	50	76	85	116	6	74	120	64	M6x6	98	M5x6	5
TK-C646	M52x1.5	29	9	50	46	87	8.5	36	RC3/8	50	76	85	116	6	74	120	64	M6x6	98	M5x6	5
TK-B846	M58x1.5	30	8	50	46	97	8.5	36	RC3/8	56	85	96	128	7	79	130	73	M6x7	110	M6x6	5
TK-A853	M58x1.5	30	8	55	53	97	8.5	36	RC3/8	56	85	96	128	7	79	130	73	M6x7	110	M6x6	5
TK-B853	M58x1.5	30	8	55	53	97	8.5	36	RC3/8	56	85	96	128	7	79	130	73	M6x7	110	M6x6	5
TK-1068	M84x2	33	9	70	68	109	12	40	RC1/2	81	108	121	164	7	98	160	98	M6x8	155	M6x8	5
TK-A1075	M84x2	33	9	80	75	110	12	40	RC1/2	81	108	121	164	7	98	160	98	M6x8	155	M6x8	5
TK-A1078	M84x2	33	9	82	78	110	12	40	RC1/2	81	108	121	164	7	98	160	98	M6x8	155	M6x8	5



- 超短，大孔徑型迴轉油壓缸，全長僅為從來型的2/3。
 - 內建逆止閥自鎖機構及壓力洩壓閥。
 - 安裝時可由後端鎖固之。
 - Super short form, light weight large Through-Hole, just as 2/3 of typical model length.
 - Built-in safety check valves and pressure relief valves.
 - Can screw it from the rear end of the cylinder when mounting.
- 專利產品字號 Patent numbers :
 台灣 : PAT.NO.M491534(Taiwan)
 大陸 : PAT.NO.ZL201420584274.5(China)

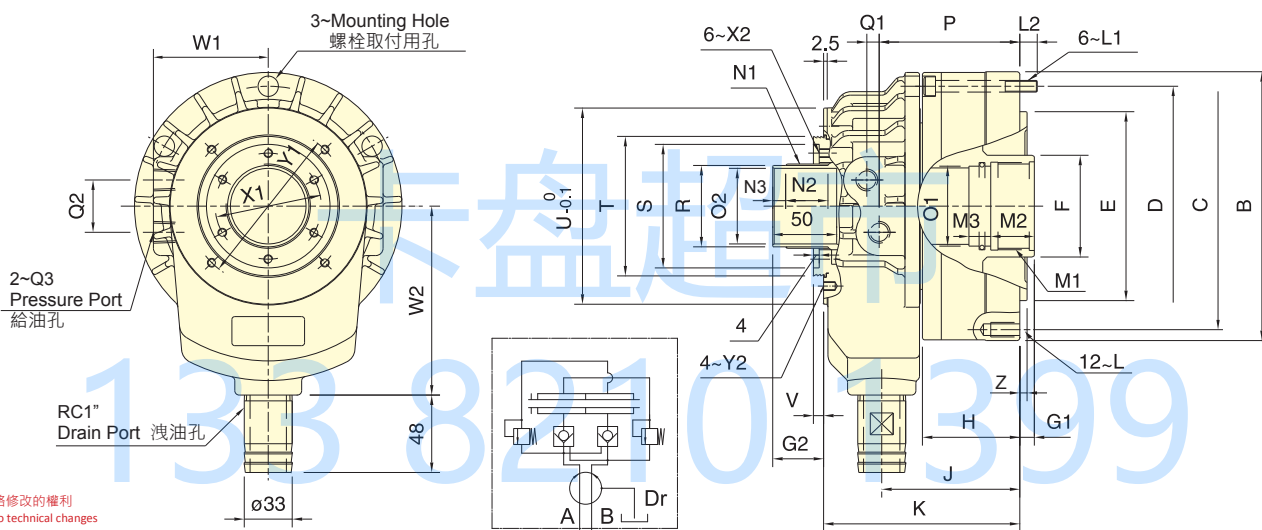

保留規格修改的權利
Subject to technical changes

技術規格 SPECIFICATIONS

型號 Model	活塞面積 Eff. piston area		行程 Piston stroke	最高迴轉數 Max. speed	最高使用壓力 Max. pressure	I Moment of inertia	重量 Weight	總洩漏量 Total oil leakage
	伸側 (Extend) cm ²	拉側 (Retract) cm ²						
TK-A1287	234.0	217.5	30	3800	4.0 (40)	0.092	24.8	4.5
TK-A1291	234.0	217.5	30	3800	4.0 (40)	0.092	24.8	4.5
TK-A1511	336.4	315.2	30	3000	3.5(35)	0.38	57.9	7.0
TK-A1512	336.4	315.2	30	3000	3.5(35)	0.38	53.8	7.0
TK-2114	373.2	336.1	35	2500	3.0 (30)	0.54	58.2	8.0

外型尺寸 DIMENSIONS

Model	A 內徑 I.D.		B	C	D	E h7	F	G1		G2		H	J	K	L	L1	L2	M1	M2	M3	N1
	max.	min.						max.	min.												
TK-A1287	200	245	215	225	180	110	30	0	59	29	86	126	184	12~M12x24	M10x90	14.5	M95x2	35	15	M99x2	
TK-A1291	200	245	215	225	180	110	30	0	59	29	86	126	184	12~M12x24	M10x90	14.5	M100x2	35	15	M99x2	
TK-A1511	250	300	275	275	230	140	30	0	58	28	102	156	226	12~M16x36	M12x110	21	M120x2	45	15	M129x2	
TK-A1512	250	300	275	275	230	140	30	0	58	28	102	156	226	12~M16x36	M12x110	21	M130x2	45	15	M129x2	
TK-2114	265	320	295	295	240	165	35	0	60	25	115	173.5	247.5	12~M16x32	M12x120	17.5	M155x2	45	20	M149x2	

Model	N2	N3	O1	O2	P	Q1	Q2	Q3	R	S	T	U	V	W1	W2	X1	X2	Y1	Y2	Z
			H8	H8					g7	H7										
TK-A1287	38	9	90	87	127.5	15	45	RC1/2	96	120	138	180	7	110	185	108	M6x10	165	M6x10	5
TK-A1291	38	9	95	91	127.5	15	45	RC1/2	96	120	138	180	7	110	185	108	M6x10	165	M6x10	5
TK-A1511	38	9	115	110	153.75	17	50	RC1/2	126	150	170	227	7	134	210	138	M6x10	210	M6x9	6
TK-A1512	38	9	125	120	153.75	17	50	RC1/2	126	150	170	227	7	134	210	138	M6x10	210	M6x9	6
TK-2114	38	9	145	140	170	17	50	RC1/2	146	170	190	250	7	145	210	160	M6x10	230	M6x10	6



- 全新短型設計，大孔徑型迴轉油壓缸。
- 內建逆止閥自鎖機構及壓力洩壓閥。
- New design, short form, light weight large through-hole.
- Built-in safety check valves and pressure relief valves.

■ 專利產品字號 Patent numbers:
 台灣: PAT.NO.M491534(Taiwan)
 大陸: PAT.NO.ZL201420584274.5(China)

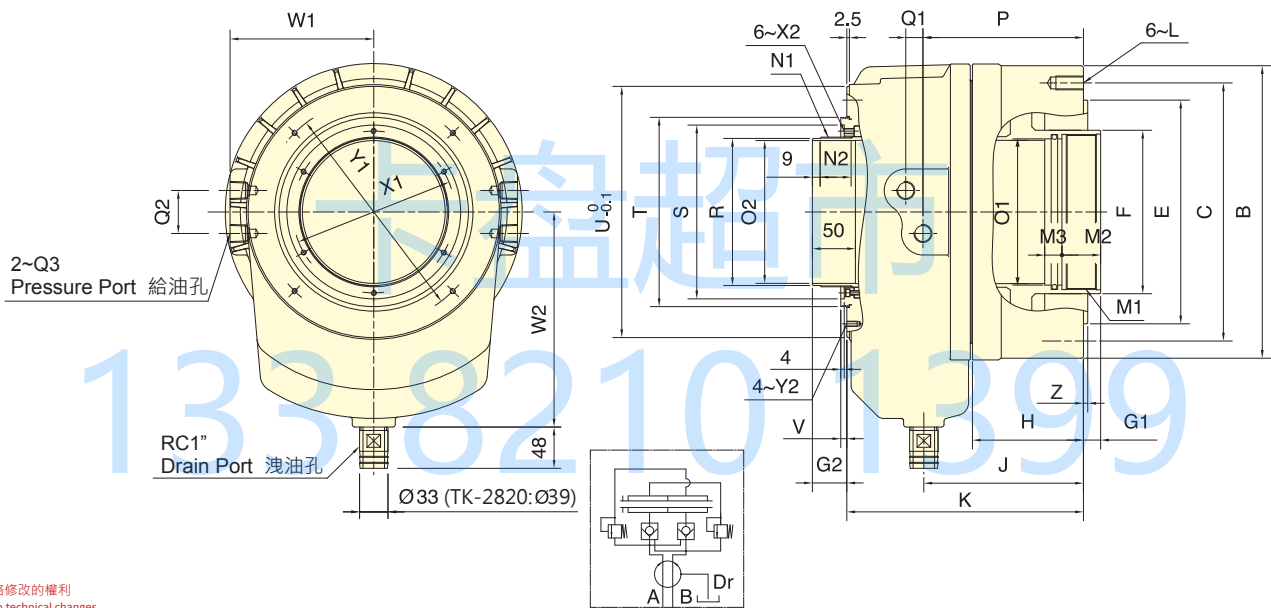

保留規格修改的權利
 Subject to technical changes

技術規格 SPECIFICATIONS

型號 Model	活塞面積 Eff. piston area		行程 Piston stroke	最高迴轉數 Max. speed	最高使用壓力 Max. pressure	I Moment of inertia	重量 Weight	總洩漏量 Total oil leakage
	押側 (Extend) cm ²	拉側 (Retract) cm ²						
TK-2416	418.4	375.4	35	2000	3.0 (30)	1.12	78.0	9.0
TK-2416L	418.4	375.4	51	2000	3.0 (30)	1.31	79.2	9.0
TK-2820	526.2	472.6	51	1600	3.0 (30)	2.4	134.0	10.0

外型尺寸 DIMENSIONS

Model	A 內徑 I.D.	B	C	E h7	F	G1		G2		H	J	K	L	M1	M2	M3	N1	N2
						max.	min.	max.	min.									
TK-2416	290	340	300	260	190	35	0	60	25	129	185.5	275	M16x32	M180x3	45	20	M174x2	38
TK-2416L	290	340	300	260	190	51	0	76	25	145	201.5	291	M16x32	M180x3	45	20	M174x2	52
TK-2820	340	395	360	320	235	51	0	76	25	152	212.5	316	M20x40	M220x3	45	20	M218x2	52

Model	O1 H8	O2 H8	P	Q1	Q2	Q3	R g7	S H7	T	U	V	W1	W2	X1	X2	Y1	Y2	Z
	TK-2416	170	166	186.5	20	50	RC1/2	171	202	220	292	7	167	250	188	M6x11	260	M6x12
TK-2416L	170	166	202.5	20	50	RC1/2	171	202	220	292	7	167	250	188	M6x11	260	M6x12	6
TK-2820	210	205	216	21	50	RC1/2	215	262	285	360	7	202.5	300	240	M6x12	320	M6x12	6