

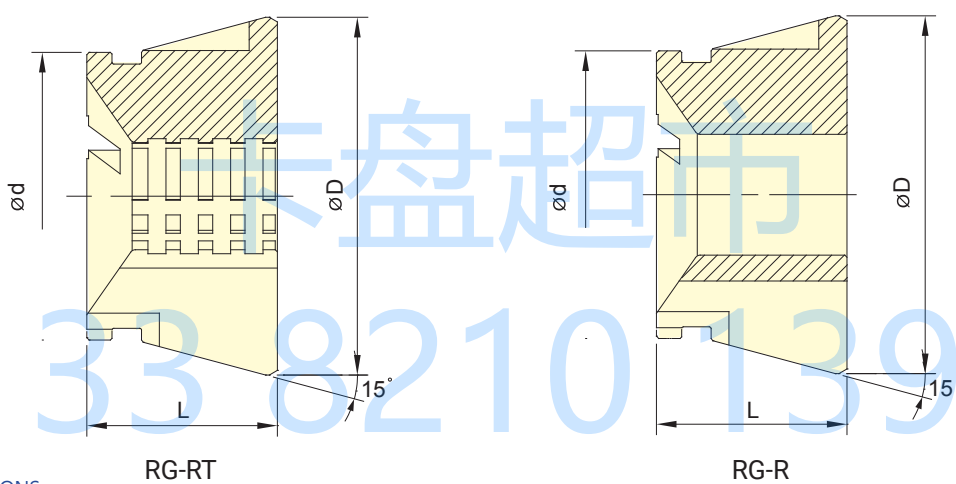

- 可用於前推式或後拉式設計的筒夾夾頭。
- 平順與接近全包覆夾持的特性，擁有更好的夾持力，且不容易傷害工件。
- 搭配單一對應工件尺寸，夾持精度可達10μm以內。
- 單一規格夾持範圍可達±0.5mm。
- 更換快速方便。
- 防塵防屑設計。
- Rubber grip collet for push type or draw type collet chucks.
- Full gripping area: high rigidity, more gripping force. Gripping smoothly: prevent to damage the workpiece.
- More accurate than standard spring collets. Accuracy: With customized rubber grip collet, the accuracy can reach ±10μm.
- Grip Range: ±0.5mm.
- Quick change and easy.
- Dust-proof and swarf-proof design.



保留規格修改的權利  
Subject to technical changes

技術規格 SPECIFICATIONS

型號 Model	最大夾持能力 Max. Chucking Capacity 圓棒 Round mm	d	D	L	適合筒夾夾頭
					Matching Collect Chuck
RG-42R	4~42	54	79.3	42	CB-42, CBE-42
RG-42RT	4~42	54	79.3	42	CB-42, CBE-42
RG-52R	4~52	66	79.3	46	CB-52, CBD-52, CBE-52, SCB-52
RG-52RT	4~52	66	79.3	46	CB-52, CBD-52, CBE-52, SCB-52
RG-65R	4~65	80	99.5	53	CB-65, CBD-65, CBE-65, SCB-65
RG-65RT	4~65	80	99.5	53	CB-65, CBD-65, CBE-65, SCB-65

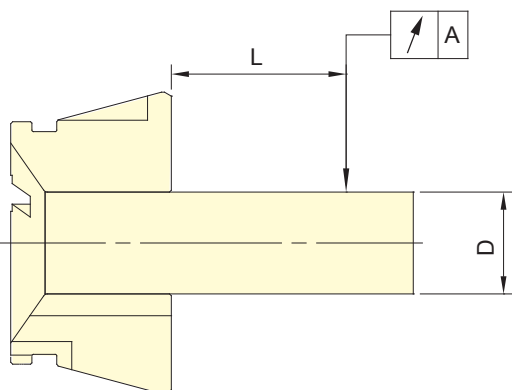

測棒 D(S,H)	L	A DIN	
Test Bar D(S,H)	mm	Class1	Class2
3.0~6.0	16	0.015	0.020
6.0~10.0	25	0.015	0.020
10.0~18.0	40	0.020	0.030
18.0~24.0	50	0.020	0.030
24.0~30.0	60	0.020	0.030
30.0~50.0	80	0.030	0.040
50.0~60.0	100	0.030	0.040

註 1：一般內筒夾精度為 DIN 二級

註 2：本公司橡膠筒夾以 DIN 一級為標準

Note1: Collets chuck are conformed to DIN 6343 Class2.

Note2: AUTOGRIP's rubber grip collets are conformed to DIN 6343 Class1.

筒夾  
夾頭